



*Ready to Perform
To Your Applications*

www.mitforklift.com.sg

© 2019 by MLAP. All Rights Reserved. All registered trademarks are the property of their respective owners. Printed in Singapore.

FMIT0158 (01/19)



PRESENTED BY :

Note: Performance specifications may vary depending on standard manufacturing tolerances, vehicle condition, types of tyres, floor or surface conditions, applications or operating environment. Trucks may be shown with non-standard options. Specific performance requirements and locally available configurations should be discussed with your Mitsubishi forklift truck dealers. Mitsubishi Forklift Trucks follows a policy of continual product improvement. For this reason, some materials, options and specifications could change without notice.



STAND-ON REACH TRUCK

RBS-CB1 Series 1.0 – 3.0 TON

EXTRAORDINARY PERFORMANCE

Pushing the Boundaries of Efficiency and Versatility

The Mitsubishi RBS-CB1 Series of stand on reach trucks is pushing the boundaries of efficiency and versatility in the robust and rapidly-evolving warehouse and logistics environment. This innovative truck promises refined performance through outstanding features like superb hydraulics, regenerative braking system, multi-mode settings and on-board diagnostics — wholly customized to meet the demanding needs of the shop floor.



Advanced AC Technology

Mitsubishi's highly-advanced AC technology powers all its trucks that are renowned for optimal control and exceptional performance. A multifunctional centralized control system features intelligent integration of sensitive hydraulic functions, multiple driving modes, and precise power management.

Customizing Operation Characteristics

Attuned to the user's spectrum of needs, the RBS-CB1 truck is sensitized to various ground conditions, including a full range of loads, speeds and modes. Its operation feeling feature is equipped for customizing acceleration, lever characteristics and response as the situation dictates. Through its unique password-protected administrative screen, the user can swiftly adjust the coordinates and manage truck performance with ease and in comfort.

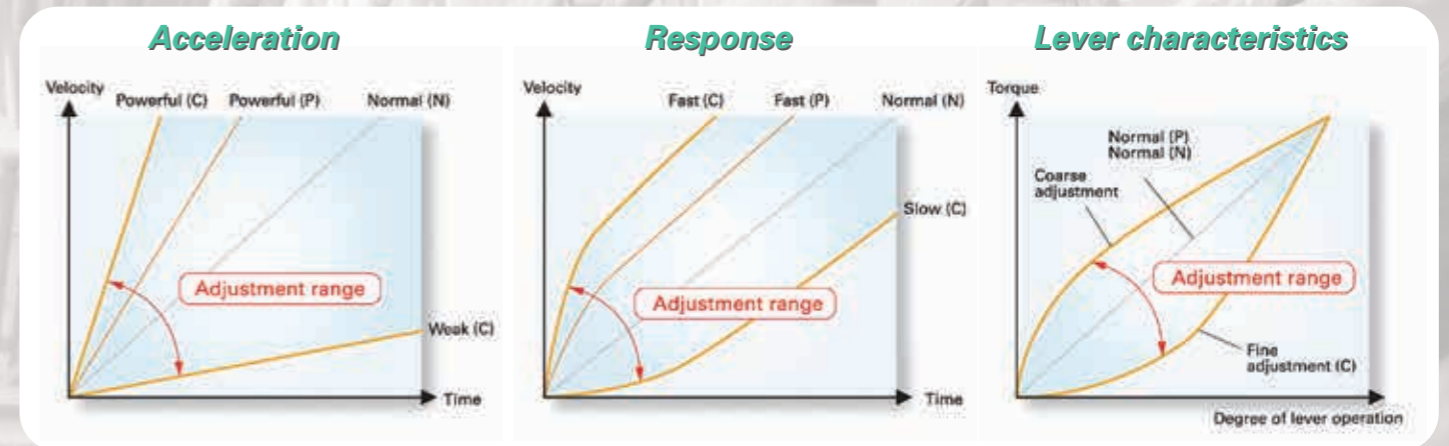

INCREASED ENERGY EFFICIENCY

Energy reduction by 15% is achieved seamlessly through enhanced engineering and improved hydraulic piping. An Eco mode switch retains the conditions of the PNC mode that reduces power consumption (speed and acceleration), and extends operation time.

Operation time and number of work cycles*2 of RBS15CB1

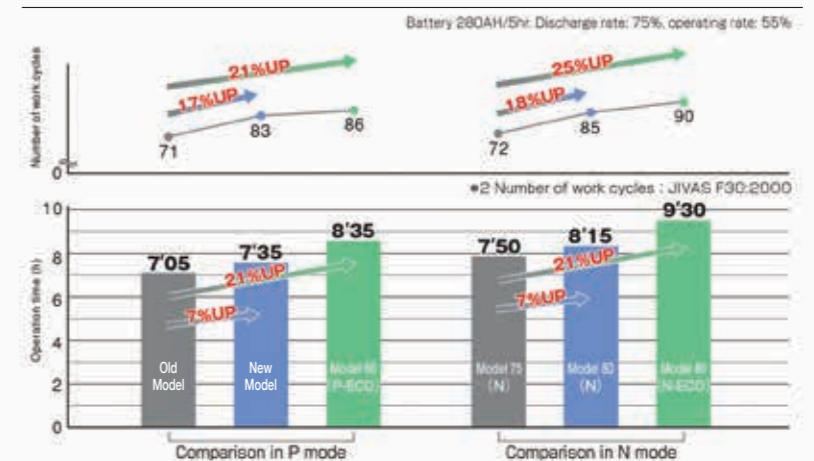

SUPERIOR ADVANTAGES

✓ Improved Stability



A newly-designed control linkage has remarkably improved the truck's overall superiority and stability, enlarging the swing angle while moving on rough ground.

A re-positioned swing lock cylinder better absorbs the movement of the control linkage, which enhances horizontal stability and the anti-slip function, and steadies the truck to lift multiple loads and make tight turns effortlessly.

Additionally, an intelligent suspension system strengthens stability on the move.

STABILITY LOCK FUNCTION

The location of the swing lock cylinder is changed to absorb the movement of the control linkage effectively.

- Left load wheel has constant contact with the ground even when turning
- Improvement of horizontal stability
- Improvement of anti-slip function
- Improvement of stability when lifting a load



✓ Improved Mast Rigidity

Critical to stability and safety, improved mast rigidity ensures superior performance with no disruption. Mast swing is reduced through an enhanced outer mast and side plate, further ensuring stability and efficiency. An improved reach cylinder with a smaller diameter also strengthens the shock-absorbing structure and achieves energy conservation.

Reinforcement of outer mast to reduce mast swing

- The same mast channel as RBS20CB1 is used for the RBS15-18CB1
- **Simplex, Duplex mast:**
 - RBS15CB1 Lifting height: 4,700 mm or more
 - RBS18CB1 Lifting height: 4,000 mm or more
- **Triplex mast:** RBS15CB1 All height
- A beam is added to the outer mast for Triplex

Improvement of reach cylinder

- Shock absorbing structure
- Smaller diameter: Contributing to energy conservation

Reinforcement of mast side plate to reduce mast swing

- Improvement of mast looseness: Strict adjustment of shims for mast rollers.

SUPREME SAFETY

Supreme safety was a top priority when designing the RBS-CB1 trucks. Refined ergonomics aside, the truck also boasts unique safety and security features, including anti-slip control, travel hydraulic interlock, emergency stop switch, and simple passcode entry system.

EMERGENCY STOP SWITCH

In the RBS-CB1 Series, this stop switch interrupts the electric power source rather than disconnecting from the battery plug. Such a direct power cut-off mode enhances safety more effectively in an emergency situation.



SIMPLE PASSCODE ENTRY SYSTEM

A simple passcode entry system protects the truck against its unauthorized operation, underscoring an important security design. This indispensable feature aids effective and easy security and safety management.

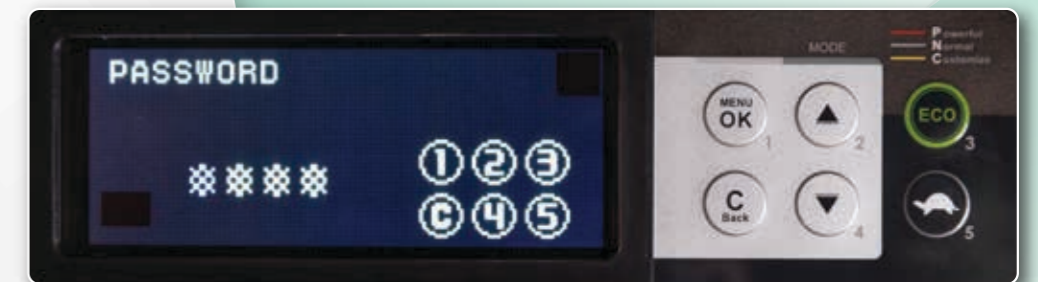

TRAVEL HYDRAULIC INTERLOCK

The operating interlock system meets strict safety measures, including ISO3691, and ensures riding comfort and efficient hydraulic operations. It automatically disables operations when the user is either out of the compartment, or in a wrong or unsafe position. The independent presence switch pedal prompts the user to take a safer posture during hydraulic operations. The alarm sounds if the situation is not right, while the travelling operation stops via its regenerative brakes before the hydraulic system halts.



ANTI-SLIP CONTROL

The anti-slip system calculates drive wheel slippage by detecting load wheel rotation and drivewheel rotation speeds through sensors. It then reduces the torque precisely in line with various speed calibrations to suppress slippage, ensuring the utmost safety.



SOLID PRODUCTIVITY

The RBS-CB1 truck boasts a solid productivity record delivered through its primary attributes of awareness, control and comfort.

AWARENESS

Transmissive LCD monitors accentuate clarity and visibility even when exposed to bright sunlight outdoors. The display with enlarged text effectively highlights the onscreen information. The displays are easy to comprehend, so monitoring is effortless.



Negative display (Normal)



Positive display (Inverted)

SELECTABLE



COMFORT

The RBS-CB1 Series is the industry standard bearer for user comfort. User conveniences include a glove compartment and a flat, magnetic document table for ease of placement and retrieval. Not offered by other brands is a compartment for storing stationery. A review of the linkage structure has led to a lower floor height without enlarging the caster wheels—ideal for the user's ease of entry and exit.

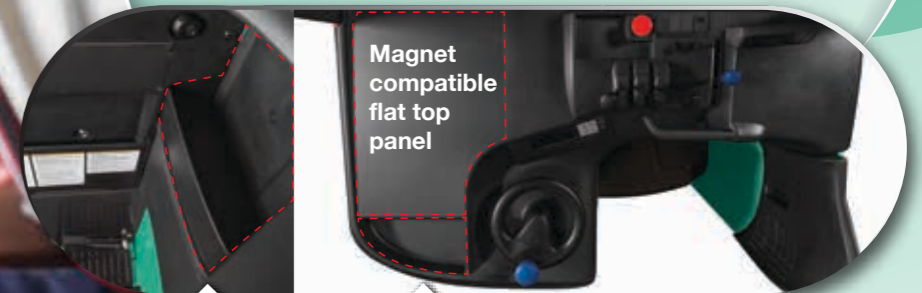

Large glove compartment

For storage of pens and small articles

CONTROL

Upgraded control elements, such as an industry-certified hand grip, contribute to overall ease of entry or exit comfort. A large, adjustable cushioned waist pad reduces user impact-stress injury and fatigue through ergonomic posturing, and also improves holding effect. The inclined steering wheel, set at an optimum angle, ensures further ease of operation.



Inclined steering wheel
The steering is set in the optimum angle for ease of operation

Hand grip
(conforming to ISO3691)
Supports ease of ingress or egress

Waist pad
A large soft cushion pad reduces operator's fatigue, and improves holding effect

SPECIFICATIONS RBS10(N)-30(L)CB1

STANDARD SPECIFICATIONS																		
Type	Item	Summary	Unit	Narrow Chassis														
				Long Wheel Base		Long Wheel Base		Long Wheel Base		Long Wheel Base		Long Wheel Base		Long Wheel Base		Long Wheel Base		
				RBS10NCB1	RBS12NCB1	RBS12LCB1	RBS15LCB1	RBS18LCB1	RBS18LCB1	RBS15LCB1	RBS18LCB1	RBS20CB1	RBS25CB1	RBS30CB1	RBS20LCB1	RBS25LCB1	RBS30LCB1	
1	Model			RBS10NCB1	RBS12NCB1	RBS12LCB1	RBS15LCB1	RBS18LCB1	RBS18LCB1	RBS15LCB1	RBS18LCB1	RBS20CB1	RBS25CB1	RBS30CB1	RBS20LCB1	RBS25LCB1	RBS30LCB1	
2	Capacity		kg	1000	1200	1200	1200	1500	1800	1500	1800	2000	2500	3000	2000	2500	3000	
3	Load center		mm	500	500	500	500	500	500	500	500	500	500	500	500	500	500	
4	Motor type			AC	AC	AC	AC	AC	AC	AC	AC	AC	AC	AC	AC	AC	AC	
5	Lift height		H ₃ mm	3000	3000	3000	4000	3000	3000	4000	4000	3000	3000	3000	4000	4000	4000	
6	Free lift		H ₂ mm	400	400	400	400	400	405	400	405	400	400	125	400	400	405	
7	Tilt angle	Down/Up	d/u deg	3/5	3/5	3/5	3/5	3/5	3/5	3/5	3/5	3/5	3/5	3/5	3/5	3/5	3/5	
8	Fork size	Length/Width/Thickness	l/b/s mm	850/100/35	850/100/35	850/100/35	850/100/35	850/100/35	920/100/38	850/100/35	920/100/38	920/122/40	920/122/40	1070/122/44	920/122/40	920/122/40	1070/122/44	
9	Fork setting	Min./Max	C mm	225 - 635	225 - 635	225 - 735	225 - 735	225 - 735	225 - 735	225 - 735	225 - 735	285 - 765	285 - 765	285 - 765	285 - 765	285 - 765	285 - 765	
10	Length	Overall length	L ₁ mm	1885	1885	1920	1920	2010	2085	2010	2175	2205	2205	2460	2205	2245	2560	
11		Frame	L mm	1475	1585	1575	1635	1705	1885	1885	1935	1915	2085	2185	2085	2155	2385	
12		To fork face	L ₂ mm	1035	1035	1070	1070	1160	1165	1160	1255	1285	1285	1390	1285	1325	1490	
13	Reach stroke		E mm	475	585	540	600	590	770	770	770	675	845	835	845	870	935	
14	Overall width	Overall width	B mm	990	990	1090	1090	1090	1090	1090	1090	1190	1190	1230	1190	1190	1230	
15		Between legs	mm	655	655	750	750	750	750	750	750	820	820	795	820	820	795	
16		Frame	mm	990	990	1090	1090	1090	1090	1090	1090	1190	1190	1190	48/350	1190	1190	
17	Height	Leg	mm	275	275	275	275	275	275	275	275	290	290	295	290	290	295	
18		Mast lowered height	H ₁ mm	1995	1995	1995	2495	1995	1995	2495	2495	2050	2050	2050	2550	2550	2550	
19		Mast extended height	H ₄ mm	3900	3900	3900	4900	3900	3900	4900	4900	3950	3950	4050	4950	4950	5050	
20	Overhead guard height	H ₅ mm	2220	2220	2220	2220	2220	2220	2220	2220	2220	2280	2280	2280	2280	2280	2280	
21	Front overhang	Reach out	x mm	175	175	175	175	185	190	185	190	195	195	190	195	190	190	
22	Floor height		mm	265	265	265	265	265	265	265	265	315	315	315	315	315	315	
23	Min. turning radius	Wa	mm	1350	1455	1455	1510	1580	1760	1760	1810	1785	1955	2050	1955	2020	2250	
24	Right angle turning aisle width	1100x1100 pallet (incl. 200mm clearance)	mm	1725	1765	1795	1815	1855	1930	1930	1960	2015	2090	2160	2090	2125	2265	
25	Right angle stacking aisle width	1100x1100 pallet (incl. 200mm clearance)	Ast mm	2520	2540	2575	2585	2670	2715	2715	2795	2815	2865	2970	2865	2915	3105	
26	Travel speed	Laden/Unladen	km/h	9.5/10.5	9.5/10.5	10.5/10.5	10.5/10.5	9.5/10.5	9.5/10.5	9.5/10.5	9.5/10.5	10/11.5	9.5/11.5	9.0/11.0	10/11.5	9.5/11.5	9.0/11.0	
27	Lift speed	Laden/Unladen	mm/s	265/450	240/450	320/540	320/540	310/540	300/540	310/540	300/540	290/490	270/490	220/400	290/490	270/490	220/400	
28	Max. Gradeability	3 min. rating, 1.5km/h and over	%	10/14.3	10/14.3	10/14.3	10/14.3	10/14.3	10/14.3	10/14.3	10/14.3	10/14.3	10/14.3	10/14.3	10/14.3	10/14.3	10/14.3	
29	Service weight	With standard battery	kg	1765	1855	1965	2065	2080	2230	2310	2430	2765	2845	3210	2925	2995	3390	
30	Number of wheels	Load/Drive/Caster		2/1/2	2/1/2	2/1/2	2/1/2	2/1/2	2/1/2	2/1/2	2/1/2	2/1/2	2/1/2	2/1/2	2/1/2	2/1/2	2/1/2	
31	Tyre	Load	mm	φ254 x 114 (Urethane)	φ254 x 114 (Urethane)	φ254 x 114 (Urethane)	φ254 x 114 (Urethane)	φ254 x 114 (Urethane)	φ254 x 114 (Urethane)	φ254 x 114 (Urethane)	φ254 x 114 (Urethane)	φ267 x 114 (Urethane)	φ267 x 114 (Urethane)	φ267 x 135 (Urethane)	φ267 x 114 (Urethane)	φ267 x 114 (Urethane)	φ267 x 135 (Urethane)	
32		Drive	mm	φ330 x 145 (Rubber)	φ330 x 145 (Rubber)	φ330 x 145 (Rubber)	φ330 x 145 (Rubber)	φ330 x 145 (Rubber)	φ330 x 145 (Rubber)	φ330 x 145 (Rubber)	φ330 x 145 (Rubber)	φ330 x 145 (Rubber)	φ330 x 145 (Rubber)	φ380 x 165 (Rubber)	φ380 x 165 (Rubber)	φ380 x 165 (Rubber)	φ380 x 165 (Rubber)	
33		Caster	mm	φ178 x 73 (Rubber)	φ178 x 73 (Rubber)	φ178 x 73 (Rubber)	φ178 x 73 (Rubber)	φ178 x 73 (Rubber)	φ178 x 73 (Rubber)	φ178 x 73 (Rubber)	φ178 x 73 (Rubber)	φ178 x 73 (Rubber)	φ204 x 76 (Rubber)	φ204 x 76 (Rubber)	φ204 x 76 (Rubber)	φ204 x 76 (Rubber)	φ204 x 76 (Rubber)	
34	Wheelbase		y mm	1105	1215	1205	1265	1335	1515	1515	1515	1515	1685	1785	1685	1755	1985	
35	Tread	Front	mm	875	875	975	975	975	975	975	975	1075	1075	1095	1075	1075	1095	
36		Rear	mm	565	565	640	640	640	640	640	640	695	695	695	695	695	695	
37	Road clearance	Center of wheelbase	mm	80	80	80	80	80	80	80	80	78	78	78	78	78	78	
38	Service brake	Mech./Hydr./Electr./Pneum.		Mech.	Mech.	Mech.	Mech.	Mech.	Mech.	Mech.	Mech.	Mech.	Mech.	Mech.	Mech.	Mech.	Mech.	
39	Parking brake	Foot/Hand/Deadman		Deadman	Deadman	Deadman	Deadman	Deadman	Deadman	Deadman	Deadman	Deadman	Deadman	Deadman	Deadman	Deadman	Deadman	
40	Battery	Voltage/Capacity (5hr. Rating)	V/Ah	24/420	24/420	48/210	48/210	48/290	48/290	48/290	48/290	48/290	48/350	48/350	48/370	48/350	48/350	48/370
41		Mass (w/case) (min/max)	kg	306 (300/450)	306 (300/450)	340 (340/450)	340 (340/450)	460 (450/750)	460 (450/750)	460 (450/750)	460 (450/750)	460 (450/750)	532 (525/900)	532 (525/900)	575 (560/900)	532 (525/900)	532 (525/900)	575 (560/900)
42	Drive motor	60 min. rating	kW	2.6	2.6	4.3	4.3	4.3	4.3	4.3	4.3	5.0	5.0	5.0	5.0	5.0	5.0	
43		Control		AC	AC	AC	AC	AC	AC	AC	AC	AC	AC	AC	AC	AC	AC	AC
44	Hydraulic motor	5 min. rating	kW	6.0	6.0	8.8	8.8	8.8	8.8	8.8	8.8	11.0	11.0	11.0	11.0	11.0	11.0	
45		Control		AC	AC	AC	AC	AC	AC	AC	AC	AC	AC	AC	AC	AC	AC	AC
46	Power steering motor	60 min. rating	kW	0.22	0.22	0.3	0.3	0.3	0.3	0.3	0.3	0.3	0.3	0.3	0.3	0.3	0.3	
47		Control		DC	DC	DC	DC	DC	DC	DC	DC	DC	DC	DC	DC	DC	DC	DC
48	Charger (option)	Type (built-in/stationary)		Stationary	Stationary	Stationary	Stationary	Stationary	Stationary	Stationary	Stationary	Stationary	Stationary	Stationary	Stationary	Stationary	Stationary	
49		Charging method		Automatic	Automatic	Automatic	Automatic	Automatic	Automatic	Automatic	Automatic	Automatic	Automatic	Automatic	Automatic	Automatic	Automatic	
50		Input	φ/V	3/(400/200)	3/(400/200)	3/(400/200)	3/(400/200)	3/(400/200)	3/(400/200)	3/(400/200)	3/(400/200)	3/(400/200)	3/(400/200)	3/(400/200)	3/(400/200)	3/(400/200)	3/(400/200)	
51	Capacity		kVA	3.4(400) 3.8(200)	3.4(400) 3.8(200)	3.8	3.8	4.7	4.7	4.7	4.7	6.5	6.5	5.2	6.5	6.5	5.2	

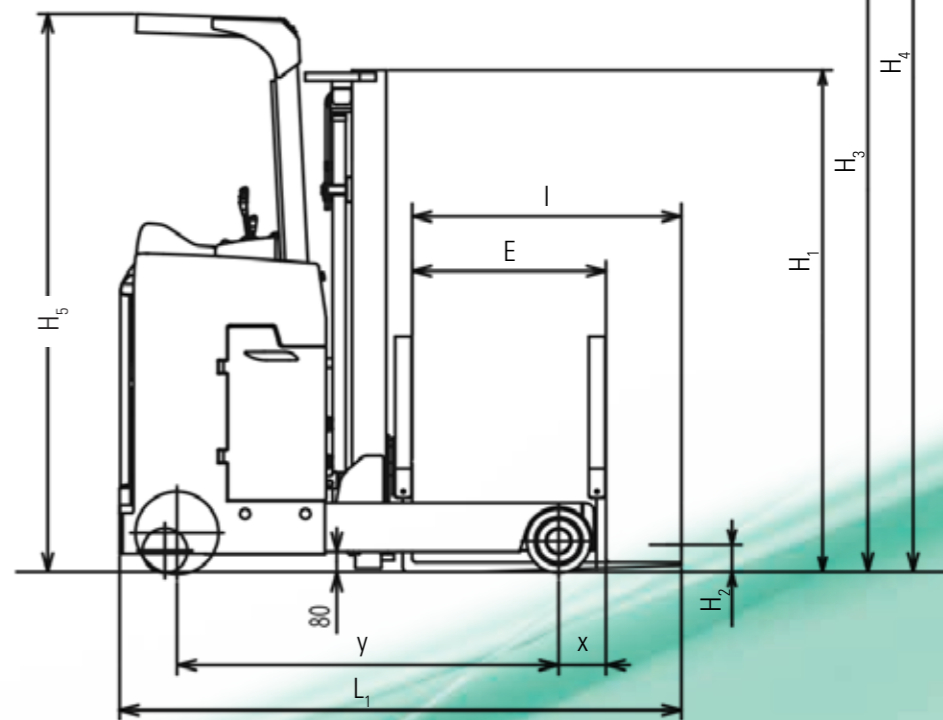
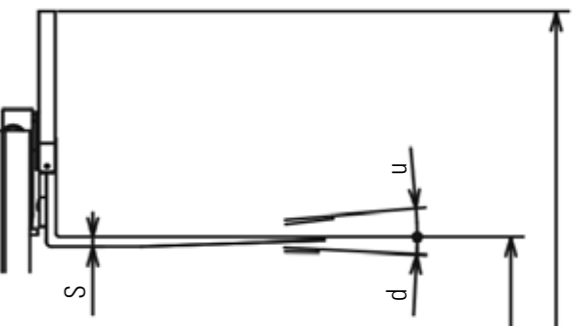
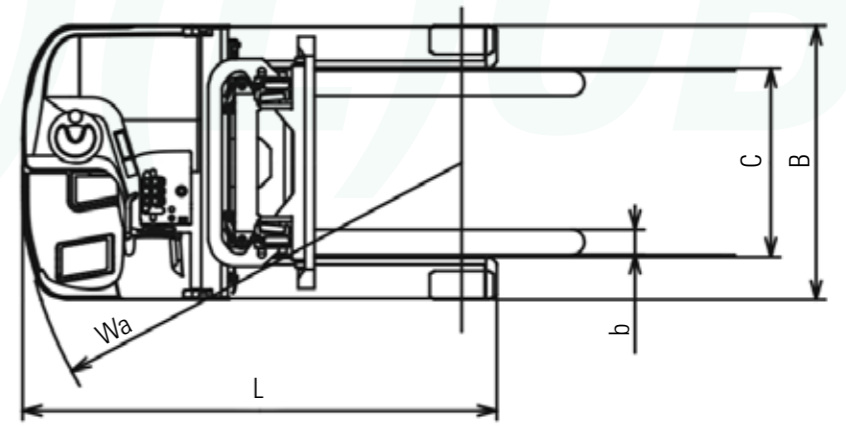

Battery Side Loading